

SAN MATEO COUNTY DEPARTMENT
OF
PUBLIC WORKS
REDWOOD CITY
CALIFORNIA

DRAWN BY: RLM
CHECK BY: MSA
APPROVED BY: NRC

SCALE: NONE
DATE: 5/98
REVISED: _____

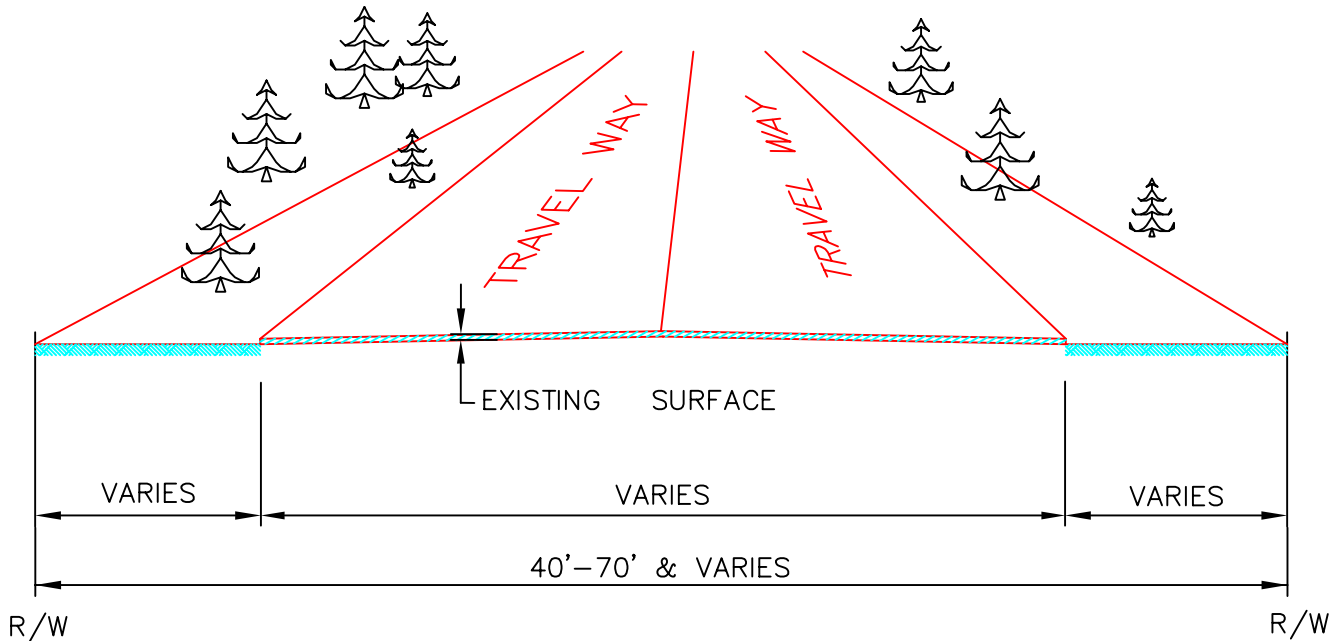

NOTE:

1. ON APRIL 28, 1998, THE BOARD OF SUPERVISORS ADOPTED RESOLUTION NUMBER 61884 ADOPTING THE CURRENT WIDTH OF THE EXISTING ROADS AS THE STANDARD FOR THE MENLO OAKS AREA AND DETERMINING THAT FUTURE IMPROVEMENTS WILL CONSIST SOLELY OF MAINTAINING THE EXISTING ROADS.
2. A FEW ROADS HAVE OTHER IMPROVEMENTS, SUCH AS CURB & GUTTER, THAT WERE CONSTRUCTED PRIOR TO ADOPTION OF THIS STANDARD.

MENLO OAKS ROAD STANDARD

NO SCALE

A-6K

SAN MATEO COUNTY DEPARTMENT
OF
PUBLIC WORKS

REDWOOD CITY
CALIFORNIA

DRAWN BY: D.P.
CHECK BY: J.A.L.
APPROVED BY: N.R.C.

SCALE: NONE
DATE: 4/97
REVISED:

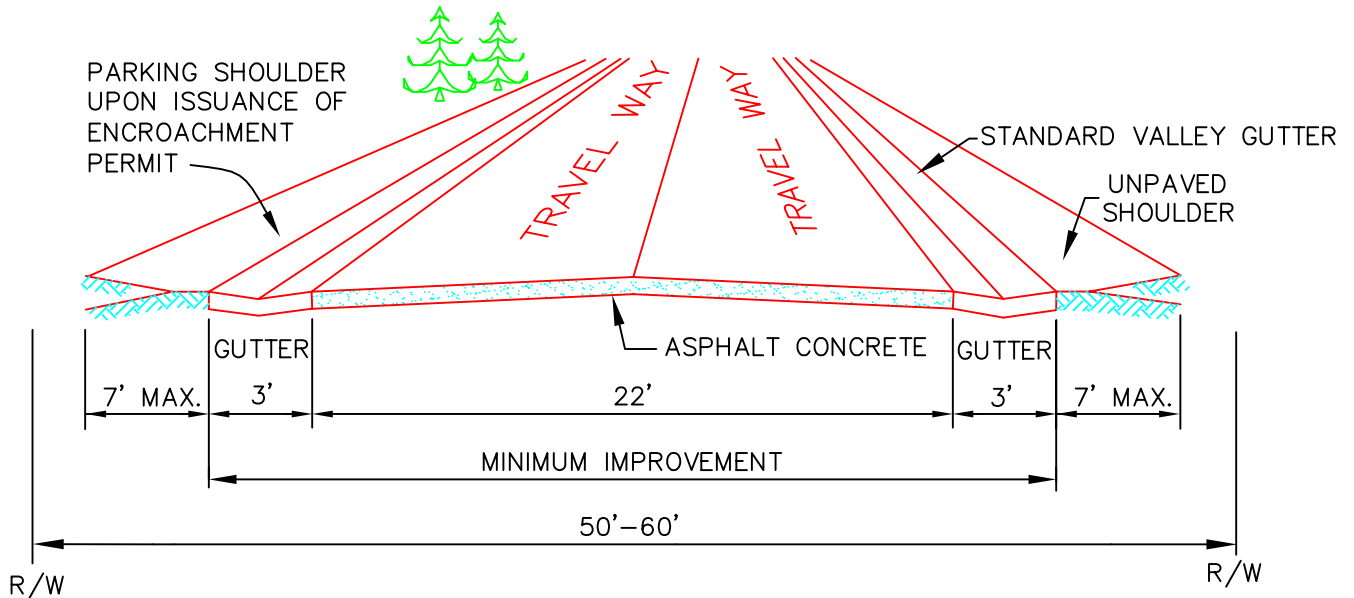

* PROPERTY OWNERS WILL ONLY BE ISSUED ENCROACHMENT PERMITS FOR PARKING WITHIN THE R/W IN FRONT OF THEIR OWN LOT.

NOTE: OTHER IMPROVEMENTS MAY EXIST THAT WERE CONSTRUCTED PRIOR TO ADOPTION OF SPECIFIC STANDARDS.

**ACCEPTABLE PARKING SURFACE FOR PARKING SHOULDER
UPON ISSUANCE OF ENCHROACHMENT PERMIT**

MATERIAL \ SLOPE	0-2%	2-7%	7-14%	14%+
UNDISTURBED GROUND	YES*	NO	NO	NO
COMPACTED EARTH	YES*	NO	NO	NO
CEMENTED EARTH	YES	NO	NO	NO
COMPACTED GRAVEL SURFACE	YES	YES	NO	NO
COMPACTED GRAVEL & OIL	YES	YES	YES	NO
ASPHALT	YES	YES	YES	YES

**MONTARA / MOSS BEACH/SEAL COVE/
PRINCETON/MIRAMAR ROAD STANDARDS**

SAN MATEO COUNTY DEPARTMENT
OF

DRAWN BY: D.P.
CHECK BY: J.A.L.
APPROVED BY: N.R.C.

PUBLIC WORKS

SCALE: NONE
DATE: 4/97
REVISED: _____

REDWOOD CITY
CALIFORNIA

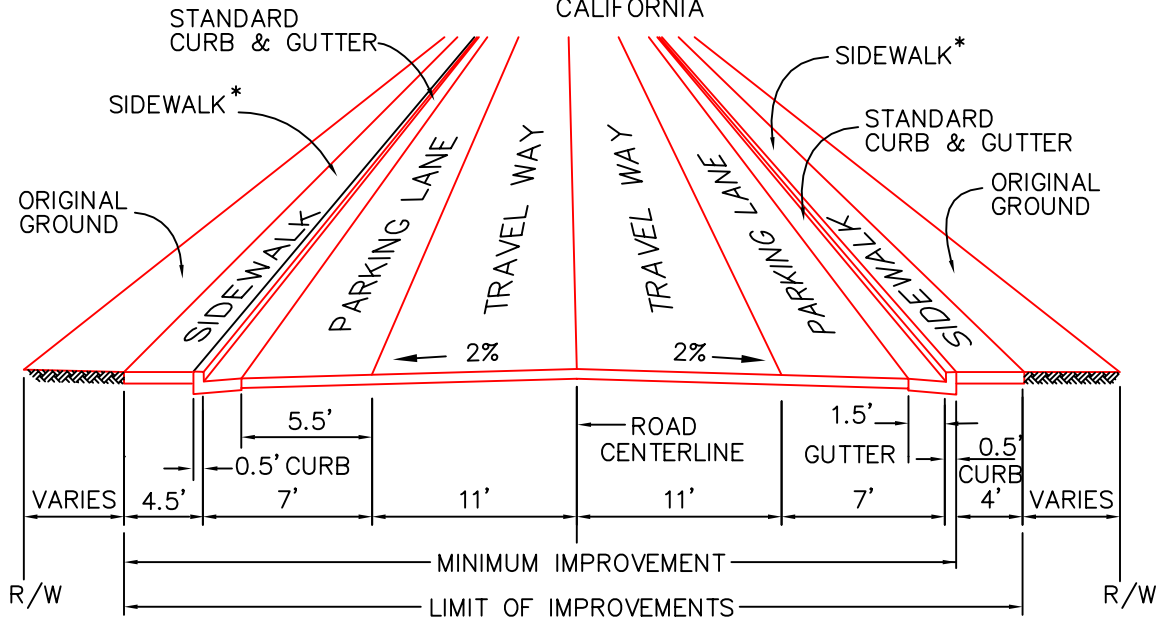

* SIDEWALKS ON ONE OR BOTH SIDES OF THE STREET,
AS DETERMINED BY PROPERTY OWNERS.

NOTE: EL GRANADA RESIDENTS CAN ALSO CHOOSE TO USE MONTARA/MOSS BEACH/
SEAL COVE/PRINCETON/MIRAMAR STANDARDS ON A PROJECT-BY-PROJECT
BASIS.

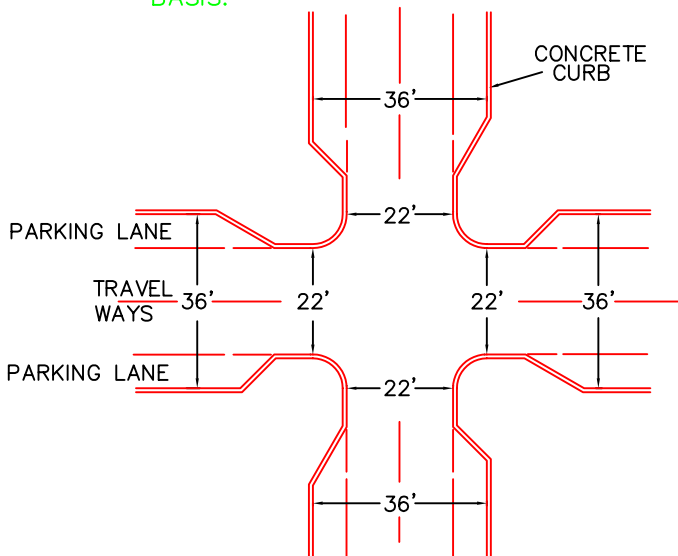

INTERSECTION DETAIL

NOTE: OTHER IMPROVEMENTS MAY EXIST THAT WERE CONSTRUCTED PRIOR
TO ADOPTION OF SPECIFIC STANDARDS.

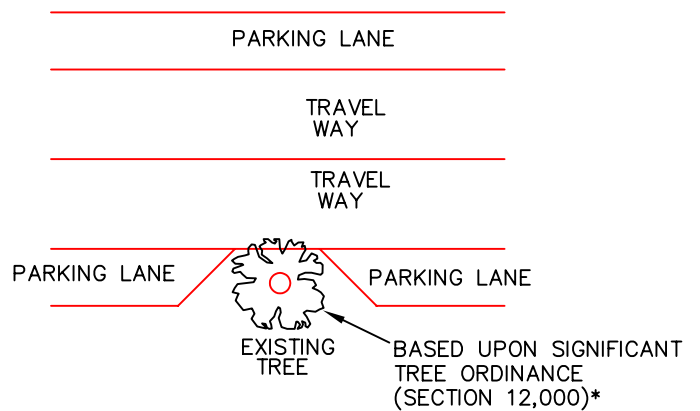

OBSTRUCTION DETAIL

* TREE HAVING MINIMUM 38" CIRCUMFERENCE (12" DIAMETER)
MEASURED 4-1/2 FEET ABOVE GROUND

EL GRANADA ROAD STANDARD

SAN MATEO COUNTY DEPARTMENT
OF
PUBLIC WORKS

REDWOOD CITY
CALIFORNIA

DRAWN BY: D.P.
CHECK BY: J.A.L.
APPROVED BY: N.R.C.

SCALE: NONE
DATE: 4/97
REVISED: _____

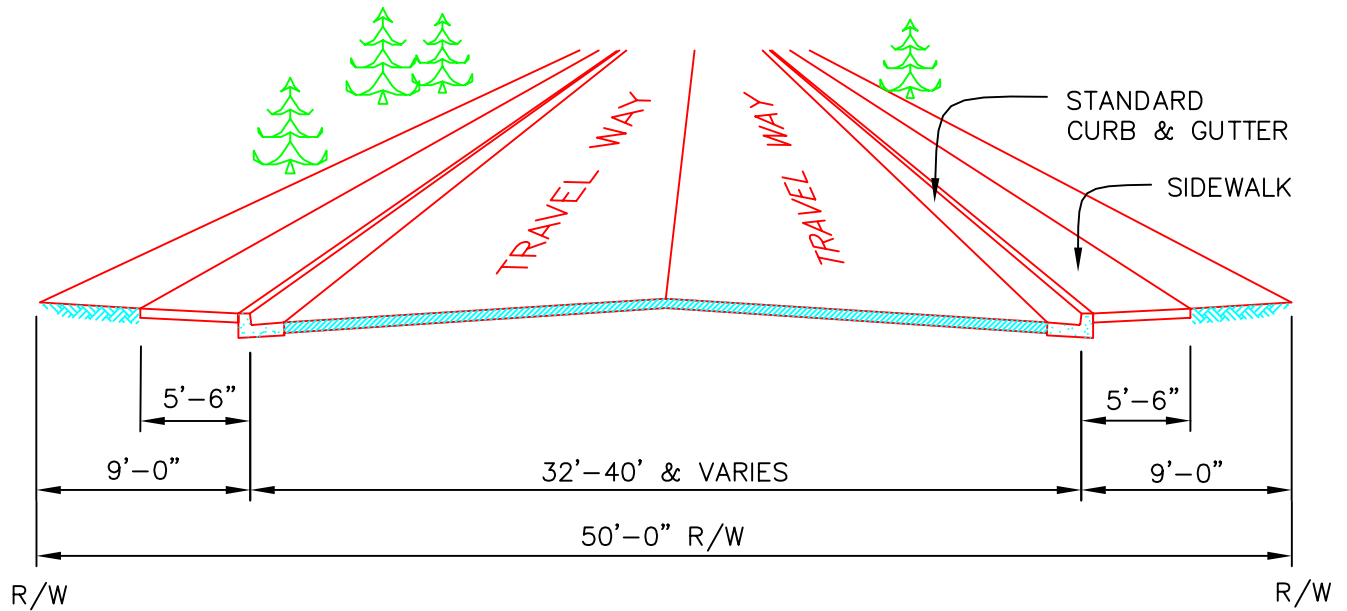

NOTE: OTHER IMPROVEMENTS MAY EXIST THAT WERE CONSTRUCTED
PRIOR TO ADOPTION OF SPECIFIC STANDARDS.

CLIPPER RIDGE ROAD STANDARD

NO SCALE

ADOPTED: OCT. 1994

A-6D

SAN MATEO COUNTY DEPARTMENT
OF
PUBLIC WORKS

REDWOOD CITY
CALIFORNIA

DRAWN BY: D.P.
CHECK BY: J.A.L.
APPROVED BY: N.R.C.

SCALE: NONE
DATE: 4/97
REVISED: 2/00

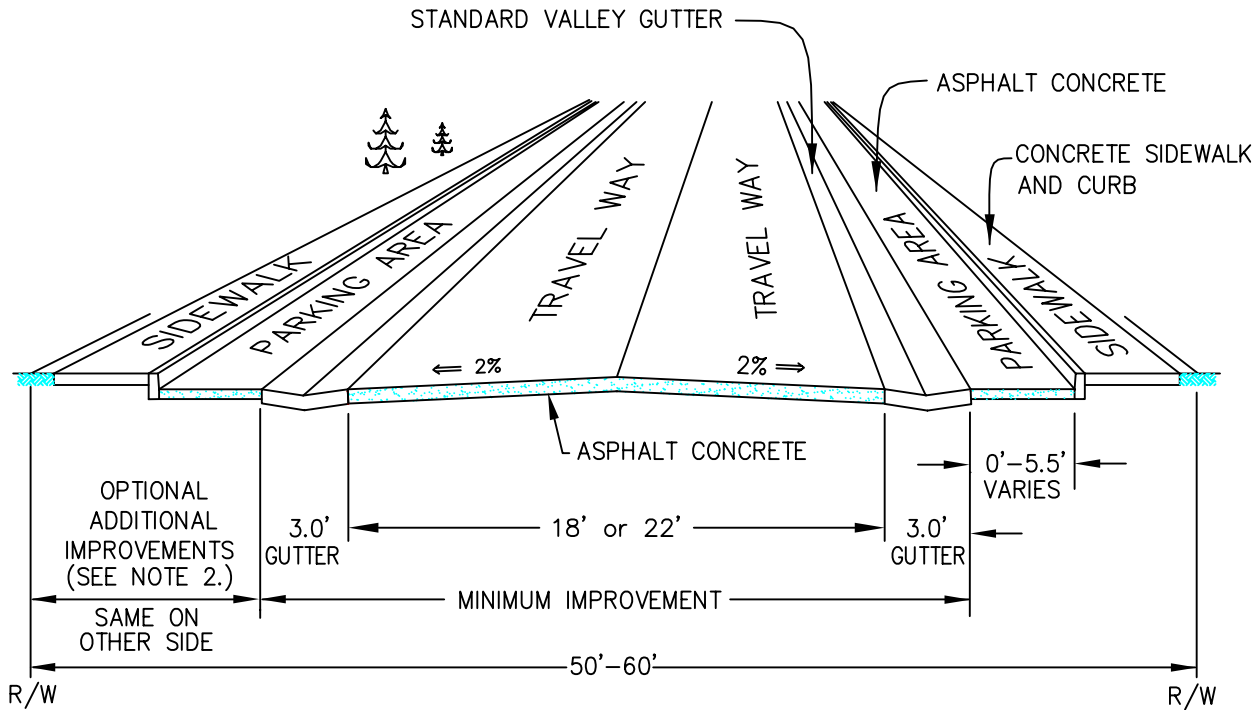

- NOTES:**
1. OTHER IMPROVEMENTS MAY EXIST THAT WERE CONSTRUCTED PRIOR TO ADOPTION OF SPECIFIC STANDARDS.
 2. OPTIONAL ADDITIONAL IMPROVEMENTS MAY BE INSTALLED AFTER OBTAINING AN ENCROACHMENT PERMIT. THE COST OF OPTIONAL IMPROVEMENTS WILL BE AT THE SOLE EXPENSE OF APPLICANT.
 3. AN 18' OR 22' ROADWAY IMPROVEMENT MAY BE BUILT, DEPENDING ON RESULTS OF A SURVEY OF THE PROPERTY OWNERS CONDUCTED BY THE PUBLIC WORKS DEPARTMENT.

SEQUOIA TRACT ROAD STANDARD

SAN MATEO COUNTY DEPARTMENT
OF
PUBLIC WORKS
.....
REDWOOD CITY
CALIFORNIA

DRAWN BY: A.G.G.
CHECK BY: J.A.L.
APPROVED BY: N.R.C.

SCALE: NONE
DATE: 2/00
REVISED: _____

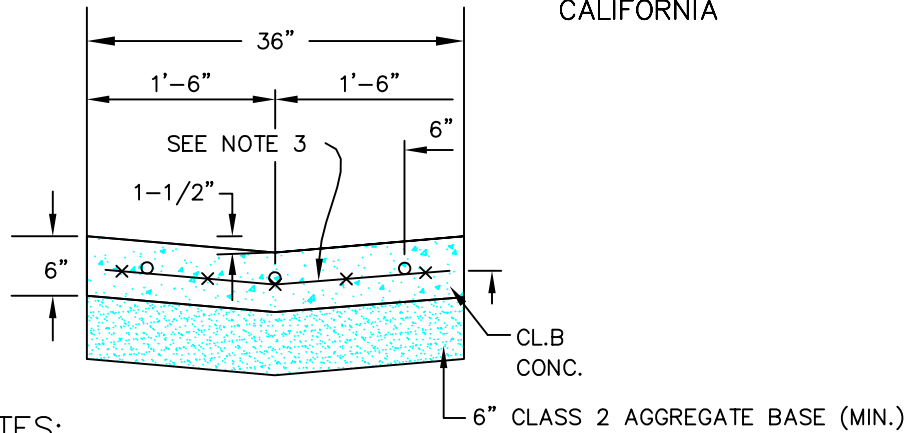

NOTES:

1. REINFORCEMENT SHALL CONSIST OF 6" x 6" - #10/#10 WELDED WIRE FABRIC.
2. CONCRETE VALLEY GUTTER SHALL BE INSTALLED PRIOR TO PAVING, UNLESS ENGINEER APPROVES OTHERWISE.
3. PLACE 1/2" DIAMETER x 18" LONG DOWELS, AT EXPANSION JOINTS, AS SHOWN.
4. PLACE 1/4" THICK EXPANSION JOINTS FULL WIDTH 20' ON CENTER.
5. SUB-BASE MATERIALS WITHIN 30" OF SUBGRADE SHALL BE COMPACTED TO 95% R.C.
6. PLACE 1/4" DEEP SCORE FULL WIDTH 20' ON CENTER, BETWEEN EXPANSION JOINTS.

CONCRETE VALLEY GUTTER

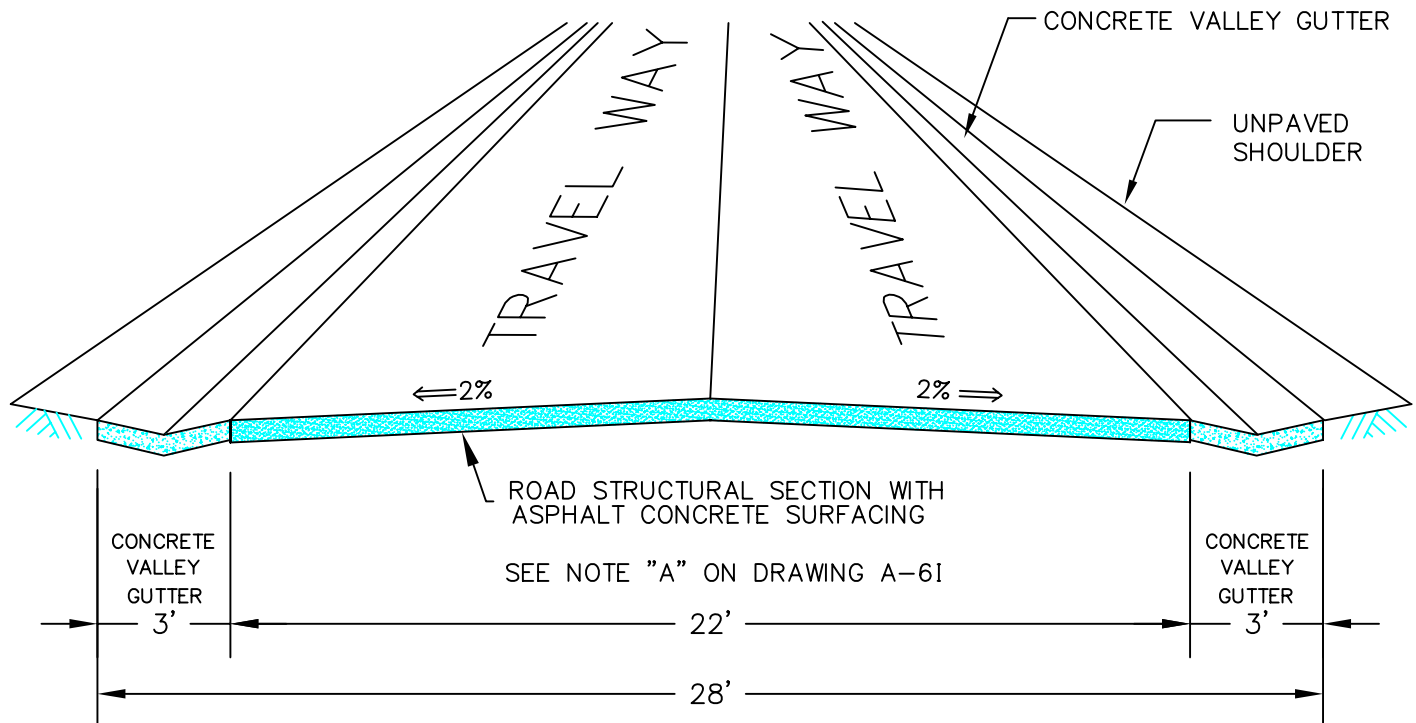

WEST MENLO PARK ROAD STANDARD

SAN MATEO COUNTY DEPARTMENT
OF
PUBLIC WORKS

REDWOOD CITY
CALIFORNIA

DRAWN BY: A.G.G.
CHECK BY: J.A.L.
APPROVED BY: N.R.C.

SCALE: NONE
DATE: 4/97
REVISED: 2/00

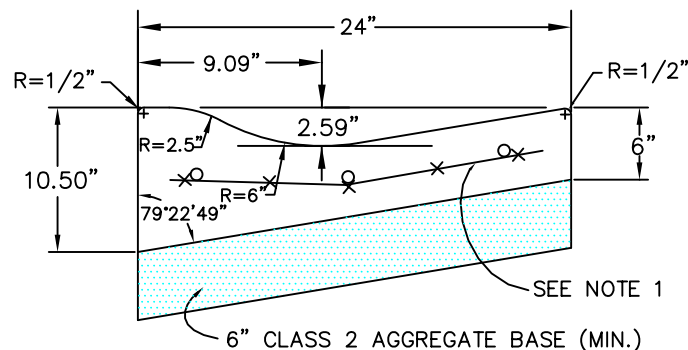

NOTES:

1. REINFORCEMENT SHALL CONSIST OF 6" x 6" - #10/#10 WELDED WIRE FABRIC.
2. CONCRETE ROLLED GUTTER SHALL BE INSTALLED PRIOR TO PAVING, UNLESS ENGINEER APPROVES OTHERWISE.
3. PLACE 1/2" DIAMETER x 18" LONG DOWELS, AT EXPANSION JOINTS, AS SHOWN.
4. PLACE 1/4" THICK EXPANSION JOINTS FULL WIDTH 20' ON CENTER.
5. SUB-BASE MATERIALS WITHIN 30" OF SUBGRADE SHALL BE COMPACTED TO 95% R.C.
6. PLACE 1/4" DEEP SCORE FULL WIDTH 10' ON CENTER, BETWEEN EXPANSION JOINTS.

2' CONCRETE ROLLED GUTTER

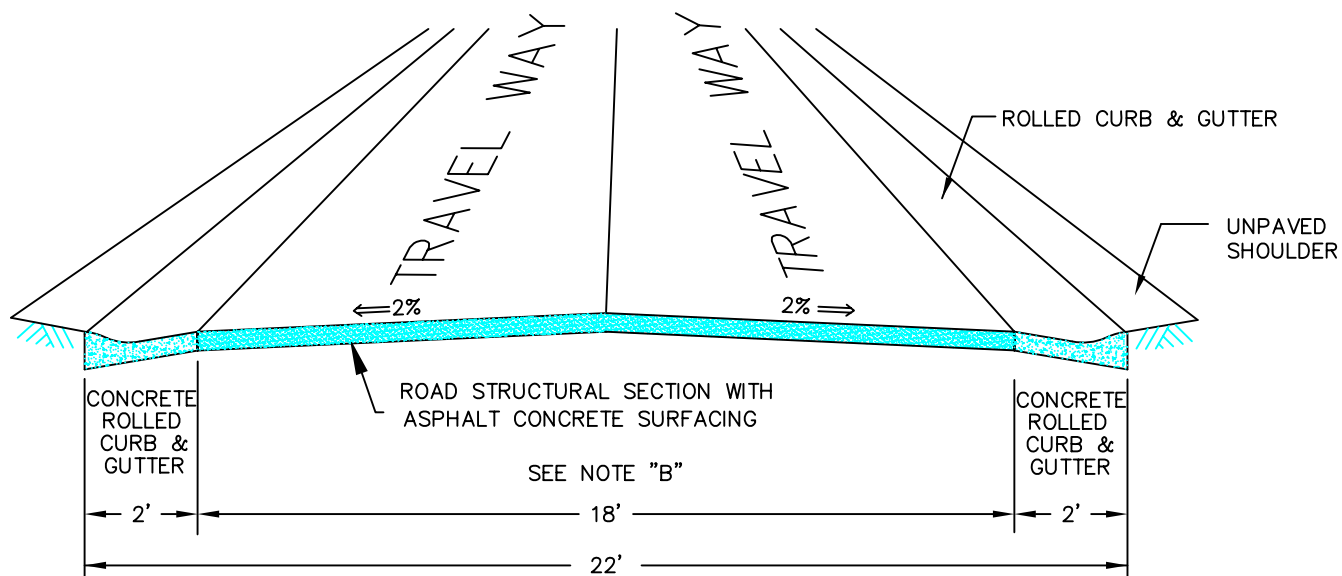

NOTES:

- A) CONSTRUCT A 22-FOOT-WIDE STANDARD WITH 3-FOOT-WIDE VALLEY GUTTERS WHERE 50% OR MORE OF THE PROPERTY OWNERS ON A FRONT FOOTAGE BASIS ON THE BLOCK INDICATE THAT THEY WANT MINIMUM IMPROVEMENTS, BUT 50% OR LESS OF THE PROPERTY OWNERS ON A FRONT FOOTAGE BASIS ON THE BLOCK INDICATE THAT THEY WANT 18 FOOT STANDARD ROAD SECTION.
- B) CONSTRUCT A 18-FOOT-WIDE STANDARD SECTION WITH 2-FOOT-WIDE ROLLED CURBS WHERE MORE THAN 50% OF THE PROPERTY OWNERS ON A FRONT FOOTAGE BASIS ON THE BLOCK INDICATE THAT THEY WANT THE 18-FOOT-WIDE STANDARD SECTION.

WEST MENLO PARK ROAD STANDARD

SAN MATEO COUNTY DEPARTMENT
OF
PUBLIC WORKS
REDWOOD CITY
CALIFORNIA

DRAWN BY: CRH
CHECK BY: JAL
APPROVED BY: NRC

SCALE: NONE
DATE: 2/00
REVISED: _____

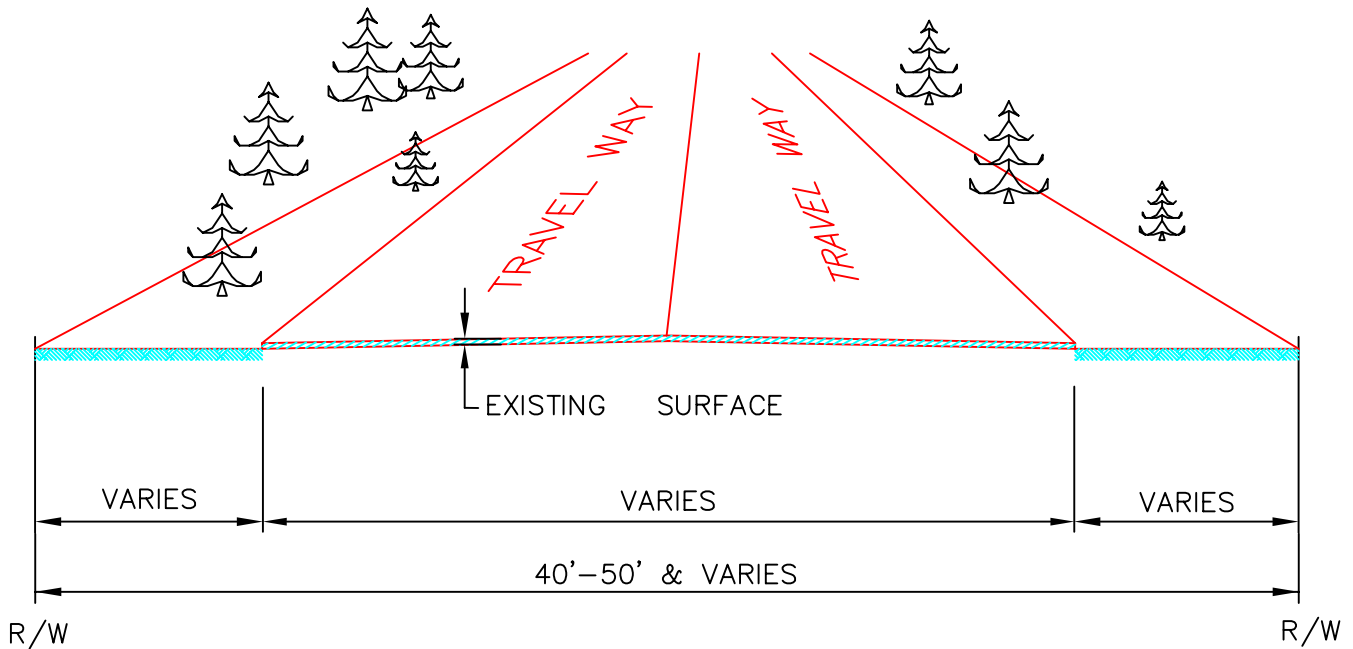

NOTE:

1. ON FEBRUARY 8, 2000, THE BOARD OF SUPERVISORS ADOPTED RESOLUTION NUMBER 63403 ADOPTING THE CURRENT WIDTH OF THE EXISTING ROADS AS THE STANDARD FOR THE DEVONSHIRE AREA AND DETERMINING THAT FUTURE IMPROVEMENTS WILL CONSIST SOLELY OF MAINTAINING THE EXISTING ROADS.
2. A FEW ROADS HAVE OTHER IMPROVEMENTS, SUCH AS CURB & GUTTER, THAT WERE CONSTRUCTED PRIOR TO ADOPTION OF THIS STANDARD.

DEVONSHIRE ROAD STANDARD

NO SCALE

A-6M